

Santos

REGIONAL INTERESTS DEVELOPMENT APPLICATION ASSESSMENT REPORT (RPI24/007) LEGHORN DEV C DEVELOPMENT

28 November 2024

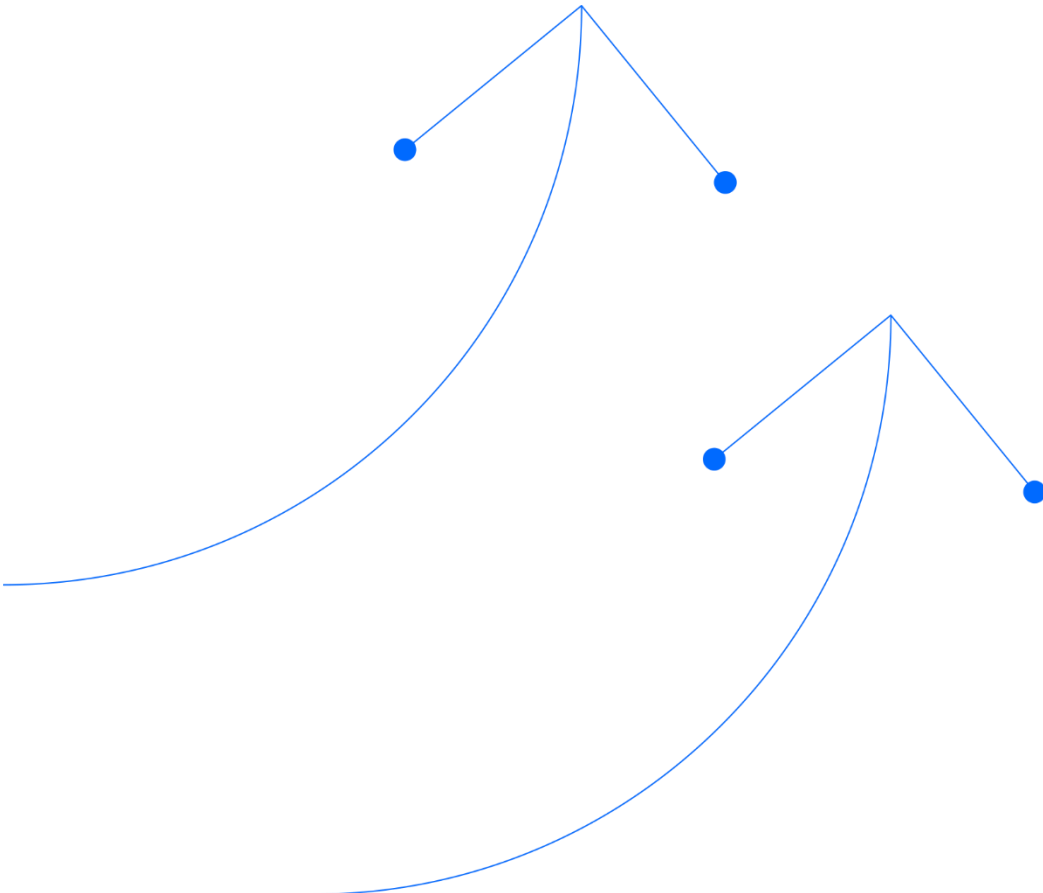

Contents

Abbreviations and Definitions	3
1. Introduction	5
1.1. Applicant and Related Approvals	5
2. Proposed Development	7
2.1. Leghorn Dev C Development Phases	9
3. Regional Attributes	14
3.2. Land Use	14
4. Environmental Attributes	16
4.1. Vegetation Mapping	16
4.2. Riparian Process and Wildlife Corridors	19
4.3. Hydrological Processes & Beneficial Flooding	21
4.4. Water Quality	24
4.5. Geomorphic Processes	24
5. Potential Impacts to Environmental Attributes and Proposed Mitigation	26
5.1. Riparian Processes and Wildlife Corridors	26
5.2. Hydrological Processes & Beneficial Flooding	26
5.3. Water Quality	27
5.4. Geomorphic Processes	28
6. Required Outcome Assessment	29
7. References	30
Appendix A – Proposed Well Lease Layout During Drilling	31
Appendix B – Typical Buried Pipeline Right-of-Way	32
Appendix C – Typical Road Cross Section for Class D Roads	33

Abbreviations and Definitions

Acronym / Term	Description
°C	Degrees Celsius
ABARES	Australian Bureau of Agricultural and Resource Economics
ATP	Authority to Prospect
BoM	Bureau of Meteorology
CDZ	Construction Disturbance Zone
DBH	Diameter at Breast-Height
DERM	Department of Environment and Resource Management, Queensland
DESI	Department of Environment, Science and Innovation, Queensland
DoR	Department of Resources, Queensland
DSDMIP	Department of State Development, Manufacturing, Infrastructure and Planning, Queensland
EA	Environmental Authority
EC	Electrical Conductivity
ENSO	El-Nino Southern Oscillation
EPBC Act	<i>Environmental Protection and Biodiversity Conservation Act 1999</i>
ESC	Erosion and Sediment Control
GAB	Great Artesian Basin
GDE	Groundwater Dependent Ecosystem
GES	General Ecological Significance
HES	High Ecological Significance
km	Kilometres
km ²	Square kilometres
Linear infrastructure	Communication and powerlines, pipelines, flowlines, roads and access tracks
m	Metres
mm	Millimetres
ML	Megalitres
NC Act	<i>Nature Conservation Act 1992</i>
P&G Act	<i>Petroleum and Gas (Production and Safety) Act 2004</i>
PL	Petroleum Lease
Proposed activities	One conventional gas well and associated infrastructure including well lease, gas flowline, access tracks and borrow pit
RDM	Residual drilling material
RE	Regional Ecosystem
RIDA	Regional Interests Development Approval
RoW	Right of Way

Acronym / Term	Description
RPI Act	<i>Regional Planning Interests Act 2014</i>
RPI Reg	<i>Regional Planning Interests Regulation 2014</i>
SEA	Strategic Environmental Area
SEP	Site Environmental Plan
Site	The footprint of the proposed activities including the outer construction boundary

1. Introduction

Santos Limited (**Santos**) is the principal applicant of Petroleum Lease (**PL**) 1055 on which the proposed Leghorn Dev C development is planned to occur. As described in **Table 1** and illustrated in **Figure 1**, the proposed Leghorn Dev C development is comprised of one new conventional gas well and associated infrastructure.

Table 1. Summary of the Proposed Development

Development Name	Development Description	Tenement	Associated EA	Property Name	Lot on Plan
Leghorn Dev C	One conventional gas well and associated infrastructure including well lease, gas flowline, access tracks and borrow pit	PL 1055	Under application	Durham Downs	1SP133822

The proposed Leghorn Dev C development is located entirely within the Channel Country Strategic Environmental Area (**SEA**) which, under Section 7 of the *Regional Planning Interests Act 2014 (RPI Act)*, is an 'area of regional interest'. A Regional Interest Development Approval (**RIDA**) is required to carry out a resource activity within an 'area of regional interest' (unless the resource activity is an 'exempt resource activity' under Part 2 Division 2 of the RPI Act, which the proposed development is not).



This assessment report has been prepared as part of a RIDA application for the proposed Leghorn Dev C development. It has been prepared in accordance with the *Statutory Guideline 01/14: How to make an assessment application for a regional interests development approval under the Regional Planning Interests Act 2014* (DSDMIP, 2019) and *Statutory Guideline 05/14: Carrying out resource activities and regulated activities within a Strategic Environmental Area* (Queensland Treasury, 2020).

1.1. Applicant and Related Approvals

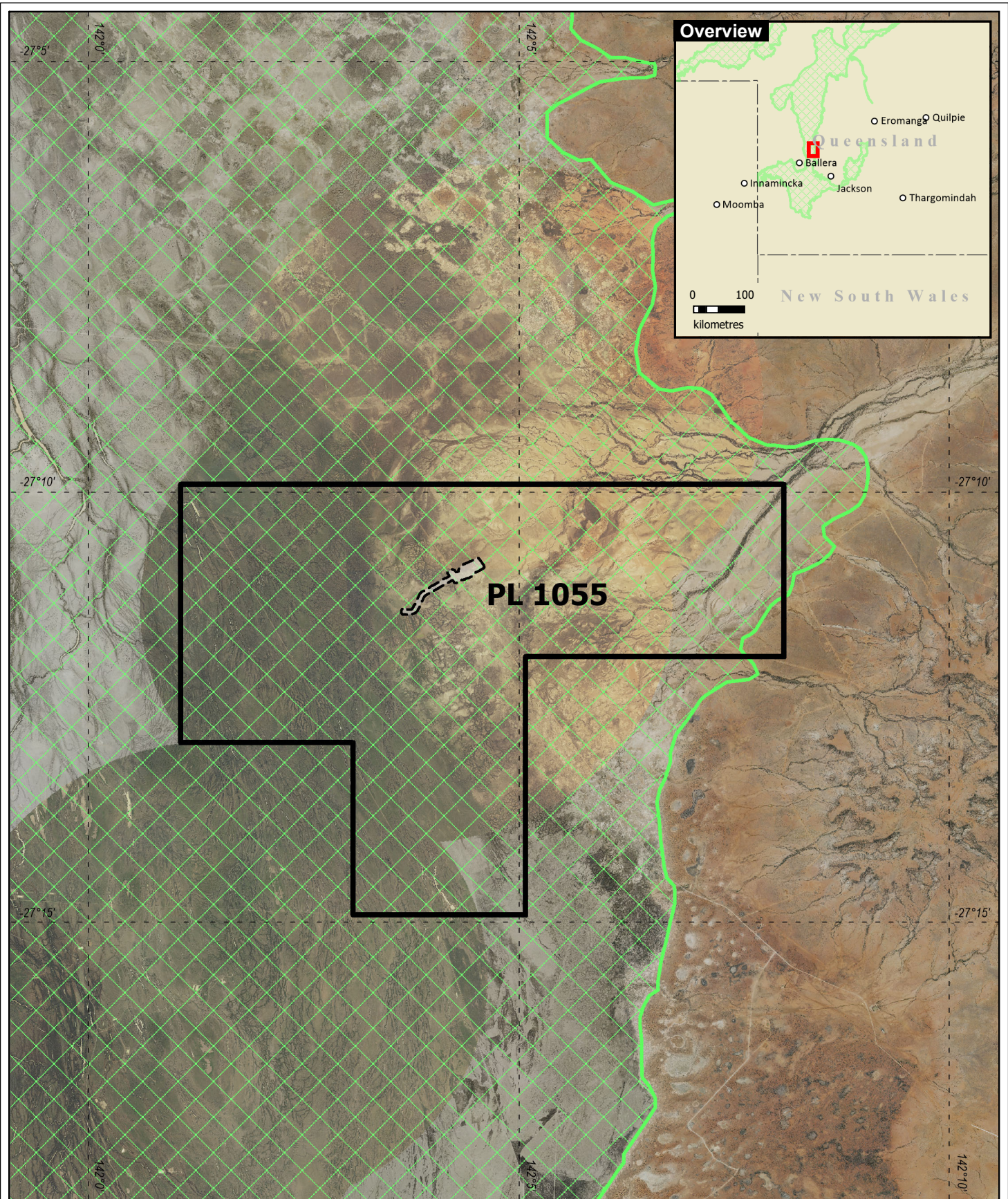
PL 1055 is currently under application in parallel with an application for a new Environmental Authority (**EA**) to replace 22 blocks from the Authority to Prospect (**ATP**) 1189 in the Cooper Basin in south-western Queensland. Santos is the primary applicant for PL 1055 and associated EA application. Santos is eligible to apply for the RIDA under section 28 of the RPI Act as per Part 5 s15 (2A), as this application relates to a petroleum resource activity involving conventional gas or oil.



Legend

-  PL 1055
-  Strategic Environmental Area
-  Construction Disturbance Zone

Certain information in this map is provided under license from third parties and is subject to intellectual property rights. Santos has made every effort to ensure that information is accurate and up-to-date but does not guarantee or warrant the accuracy, completeness or currency of, and takes no responsibility for any error or omission relating to, this map. Santos and its related bodies corporate accept no responsibility for any errors or omissions. The 'User' acknowledges that information and maps are in a constant state of change and accepts all limitations. To the maximum extent permitted by law, Santos and its related bodies corporate will not be liable for any cost, loss or damage arising out of the use of this map.

Santos

Cooper Basin

PL 1055

Regional Location or Proposed Activities

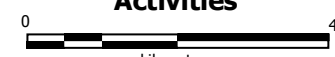

0 4
kilometres

Rev 1
Date: 19/08/2024 File No: ENVIR 1022a.WOR

Figure 1: Regional Location of the Proposed Development

2. Proposed Development

Santos is proposing to construct and operate the Leghorn Dev C development which is comprised of one conventional gas well and supporting infrastructure, including well lease, gas flowline, access track and borrow pits on PL 1055 (refer to **Figure 2** and **Section 2.1**). The maximum area of disturbance associated with the proposed development is 22.8 hectares (ha).

The proposed location of the new well and supporting infrastructure for the Leghorn Dev C development is shown in **Figure 2**. The location of the new well and supporting infrastructure has been selected in accordance with the following site planning principles:

- Maximise the use of areas of pre-existing disturbance;
- In order of preference, avoid, minimise and mitigate any impacts, including cumulative impacts, on areas of native vegetation and other areas of ecological value;
- Minimise disturbance to land that may result in land degradation;
- In order of preference, avoid then minimise isolation, fragmentation, edge effects and dissection of tracts of vegetation;
- In order of preference, avoid then minimise clearing of native mature trees;
- Maximise co-location of linear infrastructure corridors; and
- Minimise the width of linear infrastructure corridors to the greatest practicable extent.

Also shown in **Figure 2** is a Construction Disturbance Zone (CDZ) with an area of 32.2 ha. The area of the CDZ is defined to allow flexibility for final placement of infrastructure development where required due to potential constraints not discovered during scouting or detailed design phases. Preferred location for the new well and supporting infrastructure have the possibility of shifting within the CDZ to avoid cultural heritage, environmental and engineering constraints but will not move outside of the zoned area. The maximum area of disturbance within the Channel Country SEA will not exceed the disturbance outlined in **Table 2**.

The GIS files provided with this RIDA application reflect the current proposed location for the new well and supporting infrastructure as shown in **Figure 2**. Therefore, the final layout may be subject to change (within the bounds of the CDZ and maximum area of disturbance) as the design of the Leghorn Dev C development progresses.

Table 2: Proposed Resource Activities

	Location	Resource Activity	Area of Disturbance (hectares)
Channel Country Strategic Environmental Area	Lot 1 1SP133822	Leghorn Dev C	
		Well Lease	22.8
		Temporary Works Areas	
		Gas Flowline	
		Access Tracks	
		Borrow Pits	

Certain information in this map is provided under license from third parties and is subject to intellectual property rights. Santos has made every effort to ensure that information is accurate and up-to-date but does not guarantee or warrant the accuracy, completeness or currency of, and takes no responsibility for any error or omission relating to, this map. Santos and its related bodies corporate accept no responsibility for any errors or omissions. The "User" acknowledges that information and maps are in a constant state of change and accepts all limitations. To the maximum extent permitted by law, Santos and its related bodies corporate will not be liable for any cost, loss or damage arising out of the use of this map.

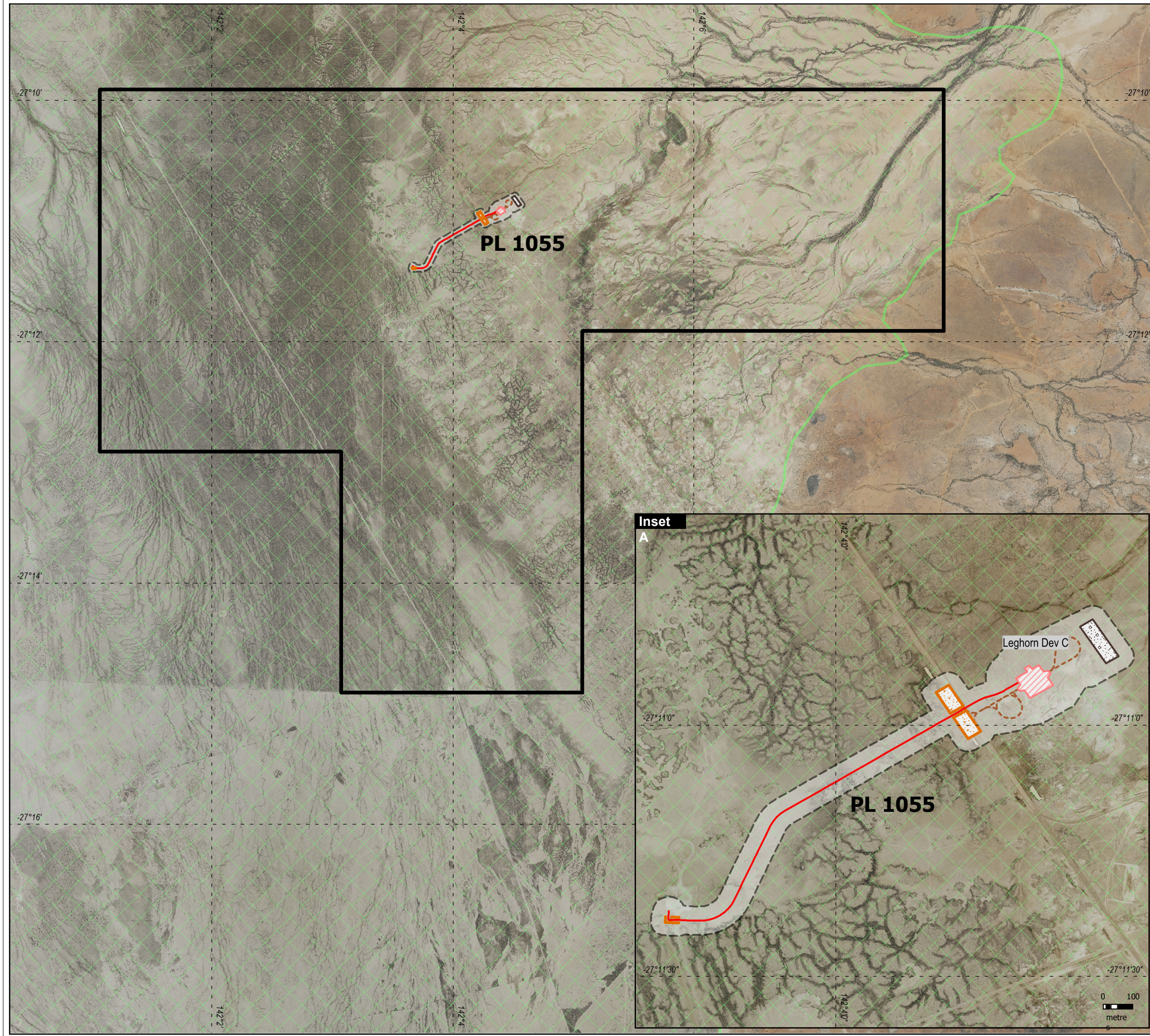

- Proposed Infrastructure**
- Access Road
 - Flowline - Gas
 - Borrow Pit
 - Temporary Work Area
 - Well Pad
- Other**
- PL 1055
 - Strategic Environmental Area
 - Construction Disturbance Zone

Santos
Cooper Basin

PL 1055
Proposed Infrastructure and
Construction Disturbance
Zone

0 100
kilometres

Rev 1 Date: 19/08/2024 File No. ENVIR 1022b.WOR

Figure 2: Proposed Infrastructure and Construction Disturbance Zone

2.1. Leghorn Dev C Development Phases

A singular well lease is proposed to be constructed to accommodate modular drilling and ancillary equipment, including a derrick, power generators, pipe handling equipment, tanks, chemical injection skid, drilling sump and associated stockpile, flare, and office area.

The operations proposed and reservoirs targeted meet the definition of conventional gas or oil as per Schedule 2 Part 5 Section 15 (3) of the RPI Regulation.

The following sections describe the design, construction, operation and decommissioning phases of the proposed Leghorn Dev C development.

2.1.1. Well Lease

2.1.1.1. Construction and Drilling

The layout of a typical well lease during drilling is provided in **Appendix A**.

Once the drilling rig is in place on the well pad, drilling will be undertaken for approximately 11 days. Drilling fluid will be continuously circulated down the drill pipe and back to the surface equipment to balance underground pressure (if required), cool the drill bit and flush out rock cuttings. A drilling fluids sump will be used to contain drilling fluids and is designed to exclude overland flow.

Drilling activities will be scheduled during periods where surface water is expected to be absent from the site, and outside of flood events/inundation periods. The well will be drilled in accordance with the Code of Practice for the Construction and Abandonment of Petroleum Wells and Associated Bores in Queensland (**Code of Practice 2019**), which are consistent with industry standards from the American Petroleum Institute (**API**) and the International Organisation for Standardisation (**ISO**). These standards provide minimum construction requirements and good industry practice for petroleum production. The preliminary well design is a 2-string design with 7-5/8" steel surface casing and 3-1/2" chrome steel tubing. These strings will be cemented either back to surface or to inside the previous casing.

Following the completion of drilling, the drilling rig will be transported from site and partial rehabilitation will commence. Drill fluids may remain in-situ for a short period of time whilst operations are occurring. Waste drill fluids / sump liquids will be removed and relocated to a suitable location (e.g. nearby active sump or a dedicated pond for processing or licensed waste facility).

2.1.1.1.1. Residual drilling material

If residual drilling material (RDM) is to be within a sump, Santos will comply with the EA conditions L4 - L6 of ATP 1189 (EPPG03518215) unless otherwise specified within the new EA approval. The mix-bury methodology will be applied and evidence of compliance with the certified burial methodology will be retained. Santos currently implements a specific approved burial methodology that complies with the mix-bury cover method and will align with the EA condition set, once approved. It is expected that sumps will be backfilled within six (6) months of drilling completion. This timeframe exists to ensure that the sump is sufficiently dry prior to backfilling.

2.1.1.1.2. Erosion and Sediment Control

Santos implements a specific Site Environmental Plan (**SEP**) for capturing the various stages of development activities which includes controls around the management of stormwater and erosion and sediment control during the different phases of the project. Monitoring will be undertaken at a frequency that is appropriate to demonstrate compliance with the potential EA condition set.

Stormwater will be managed in accordance with Santos internal processes which aligns with typical EA condition sets (e.g. conditions B11 and B14 of the existing ATP 1189 EA (EPPG03518215)), to prevent contact with the drill material and the release of any contaminated waters. These processes enforce drill sumps to be constructed in a way that prevents overland flow entering the sump (i.e. contoured/earth bunded to prevent surface water entry) and manage commensurate site-specific risk of erosion and sediment release.

Prior to disturbance being stabilised, and as part of the SEP during the construction/initial disturbance phase of projects, Santos conducts regular inspections of integrity and suitability of controls.

2.1.1.2. Operation

During operation of the well, surface facilities will be used for the purpose of petroleum production. Surface facilities will include the wellhead and a tie-in riser. The wellhead consists of equipment which supports the various pipe strings, seals off the well, and controls the paths and flow of reservoir fluids. The tie-in riser connects the well to the flowline and enables transportation of the extracted petroleum.

Well stimulation techniques including hydraulic fracturing may be used to increase the recovery of resources (in this case, gas) by increasing the permeability of the reservoir. Hydraulic fracturing involves pumping a fluid under pressure into the reservoir to open and connect fractures within the reservoir rock, thereby increasing the opportunity for the resource to move within the reservoir rock and flow toward the well. After the fracture process is completed, fluids that return to surface when the pressure is released are captured for reuse, recycling or transported to a licenced water management facility.

It is feasible that workover operations will be required for the well in the future. Workover operations include activities such as cleaning out of production conduits and replacing tubing, retrieving or drilling out obstructions in the well and well bore decommissioning. For applicable workovers, a workover rig and associated infrastructure (i.e. a drilling fluids sump) will need to be setup within the proposed disturbance footprint for a temporary duration. Workover operations will also be scheduled to be completed when no surface water is expected to be present on site and outside of flood events/inundation periods.

2.1.1.2.1. Stimulation Impact Monitoring

Santos will ensure stimulation fluids are effectively managed by implementing Santos' South-West Queensland Stimulation Impact Monitoring Program (**SIMP**) to provide guidance of stimulation activities, whilst ensuring compliance to conditions K10 - K15 of the current ATP 1189 associated EA and any future EA related conditions. As per SIMP, all flowback will be collected either in onsite storages (and then transported to a fluid handling facility) or transported through the gathering system to a centralised facility for treatment and disposal. Post stimulation activities, representative flowback sampling is to be undertaken in accordance with the SIMP and is to be completed when flowback or produced water is recovered at surface. A flowback or produced water sample is to be collected post stimulation on each well and analysed for the analytical suite detailed in the SIMP.

2.1.1.3. Rehabilitation and decommissioning

Where possible, Santos will leave ground undisturbed to minimise rehabilitation required. Rehabilitation of disturbed areas will take place progressively as works are staged as per the EA condition set. In addition, the rehabilitation of significantly disturbed areas that are no longer required for on-going activities will commence within 12 months (unless an exceptional circumstance in the area to be rehabilitated (e.g. a flood event) prevents this timeframe being met).

The associated EA typically has progressive rehabilitation requirements for disturbance during construction. All progressive rehabilitation will be aligned with the relevant conditions of the EA for PL 1055 (once granted). To ensure the suitable rehabilitation methods are implemented, an SEP will provide rehabilitation requirements which aligned to approval conditions (RIDA and EA related).

The well will be decommissioned at end-of-life in accordance with the requirements of the *Petroleum and Gas (Production and Safety) Act 2004* (P&G Act 2004) and the relevant conditions of the EA for PL 1055 (once granted).

2.1.2. Buried Gas Flowlines

To commercialise gas from the well, a buried gas flowline is required to connect the well to existing gas gathering infrastructure. The flowline will consist of a 100-millimetre (**mm**) diameter (DN 100) steel pipe, buried to a depth of around 750 mm.

2.1.2.1. Construction

A Right-of-Way (**RoW**) width of approximately 15 m is required for installation of the proposed buried gas flowline. This area comprises the topsoil bank on either side of the RoW, access for pipe truck and side boom tractor/excavator, the flowline trench, and a trench spoil bank (refer **Appendix B** for typical layout).

Once the flowline is laid within the trench, it will be tested, bedded with padding placed around it, backfilled and compacted. Hydrotest water will not be released to land; it will be transported to the nearest licensed water management facility for treatment and/or disposal.

2.1.2.1.1. Erosion and Sediment Control

The installation of the flow lines will be undertaken in such a way as to prevent significant disturbance to the current soil profile and site topography which would abide by the future EA conditions containing methodologies for topsoil removal for construction activities:

- RoW topsoil will be stripped where required and stored separately for later use in rehabilitation;
- Any stripped soil remains 10 m from watercourses;
- Where at all possible, Santos will leave ground undisturbed to minimise rehabilitation required.

Santos will ensure the original topography of the site will be re-established following the installation of the proposed flow lines and RoW by capturing sufficient evidence of site condition at initial scope assessment prior to construction. Photographic evidence of the original topography will be collected and retained as evidence for re-establishment. After completion of the RoW, reinstatement with the original stored topsoil and seed stock will proceed.

As per past SEPs implemented prior to construction activities occurring (which captures any approval conditions), the RoW topsoil will be stripped where required and stored separately for later use in rehabilitation. Any stripped soil must remain 10 m from watercourses, for protection from erosion and sediment transportation. Where possible, Santos will leave ground undisturbed to minimise rehabilitation required.

The RoW will then be reinstated to the condition and profiles existing at the commencement of activities. All wheel and equipment ruts along the flowline route will be filled in and levelled by grading. Topsoil and seed stock removed during installation will be re-spread over the RoW and windrows removed. Where seed stock has not been displaced during installation, the area will be lightly scarified to promote regrowth.

2.1.2.2. Operation

Once operational, the flowline will transport gas from the well into existing gas gathering infrastructure. Pipeline maintenance activities, such as pigging and inspections would also be carried out from time to time. A maximum three (3) m wide corridor within the rehabilitated RoW will be used for the inspections via light vehicles. No formed roads will be required.

2.1.2.3. Rehabilitation and decommissioning

The proposed timeline for rehabilitation following the installation of the flow lines will be implemented progressively. In accordance with the EA conditions for projects within the vicinity of Leghorn Dev C, the rehabilitation of significantly disturbed areas that are no longer required for on-going activities will commence within 12 months (unless an exceptional circumstance in the area to be rehabilitated prevents this timeframe from being met (e.g. flood event)).

The flowline will be decommissioned at end-of-life in accordance with the P&G Act and the relevant conditions of the EA for PL 1055 (once granted).

2.1.3. Access Tracks

Approximately 945 metres (m) of new access track would be constructed to provide access to the wells lease and borrow pit.

2.1.3.1. Construction

The proposed access track will be up to 13 m in width to accommodate a trafficable roadway and table drains either side of the roadway, spaced out as per Santos Class D Road classification spacing recommendations (refer Appendix C for typical layout).

Santos will construct roads to 6 m to 8 m wide running surface, requiring additional 1-2 m either side of the running surface for table drains / topsoil / seed stock / veg stockpile (standard drawings available).

Access track width may increase above 8 m when cutting into areas of elevated topography. Dunes are required to be saddled to construct suitable approaches and will be constructed at the higher road width to allow vehicles to pass alongside and maintain speed to transverse dunes despite the reduced line of sight.

The roadway will be graded and capped with clay or similar locally available borrow pit material. Flood ways / creek crossings will remain free of any such features / bunds and constructed at bed level. This will cover activities such as rehabilitation of the road where Santos may need to go beyond the original constructed width to pull back in windrows / topsoil over the road.

2.1.3.1.1. Erosion and sediment control

There are a number of land types situated in Santos' working tenements in SWQ. Each land type requires to be approached differently depending on the type of works, machinery required and EA conditions. The SEP considers these factors and implements internal instructions for the life of the project which are tailored to the unique landforms it operates on.

To aid in managing erosion and sediment control, Santos will construct floodways to match the general topography of the site and reticulate dunes to be crossed perpendicular to minimise disturbance, although they are all fairly deflated in this area.

Road alignment preferentially avoid areas of with significant vegetation being located. Access alignments in this application do not cross any channels with significant riparian vegetation.

Blade work for access tracks will be kept to a minimum. Track preparation should only be sufficient to meet the needs of vehicles accessing the site. Wherever possible, vehicles will be driven across the unprepared terrain (i.e. 'surface trafficking'), particularly in areas of low or sparse vegetation, gibber, or scree surfaces.

Where there are no established tracks and it is intended to traverse the same ground more than once, the same wheel tracks should be used each time.

Where vegetation or terrain makes surface trafficking impractical, the following options are typically considered in the SEP:

- 'Walking a dozer' (i.e. keeping the blade ~0.3 m above the ground).
- Slashing vegetation.
- Rolling back vegetation or driving a dozer back and forth in low scrub to crush stakes.
- Using a scrub rake in front of a small dozer or 4-wheel-drive to clear wheel tracks.

2.1.3.2. Operation

The proposed access track will be used for ongoing access to the well lease and supporting infrastructure. The proposed access track will be designed to convey natural surface water flows consistent with the existing hydrology and will not be accessed during prolonged wet weather.

2.1.3.3. Rehabilitation and decommissioning

To ensure the suitable rehabilitation methods are implemented, an SEP will provide rehabilitation requirements which aligned to approval conditions (RIDA and EA related) and relevant landscape.

During the decommissioning, progressive rehabilitation will take place with the following aspects typically in place:

- Be a stable landform, exhibiting no subsidence or erosion gullies.
- Be re-profiled to a level consistent with surrounding soils.
- Be re-profiled to original contours and established drainage lines.
- Plant pest species (restricted matter) are not present or are consistent with the surrounding areas.
- There must be no significant subsoil on the surface.
- No subsidence is to be evident.

At the end of operations, in addition to the above, all access tracks will be rehabilitated in accordance with the relevant conditions of the EA for PL 1055 (once granted) or left in place for future use by the landholder, subject to agreement.

2.1.4. Borrow Pit

One (1) new borrow pit will be established, within close proximity to the well lease. This borrow pit will be used to provide a source of material for the construction of new infrastructure and ongoing maintenance of the well lease and access tracks associated with the proposed activity.

2.1.4.1. Construction

The total area of the proposed borrow pit will be 0.8 ha. This disturbance area is required for project facilitation and is inclusive of the work area surrounding the pit, seedstock pile, excavation machinery turning point, and the quarried pit. The proposed quarried pit will be 6000 square metres (m²) and excavated to a maximum depth of 3 m; the volume of this pit is approximately 12 megalitres (ML).

2.1.4.1.1. Erosion and sediment control

The management of erosion and sediment during the life of the project are managed through the implementation of an SEP and regular inspections during construction phases.

Santos' primary measure to exclude the capture of overland flow is locating borrow pits outside of flood ways and channels where possible. Where no reasonable or practicable alternative exists, Santos will locate borrow pits in pre-existing areas of clearing of significant disturbance. The order of preference is captured during the planning stages of proposed development.

To prevent overland flow into the pit, all borrow pits will be constructed with a perimeter berm surrounding the borrow pit, constructed at 0.5 m high and 3 m wide. The side batters of the borrow pits will be maintained at a slope of approximately 6:1 (3:1 maximum) and the batters of the entrance/exit will be maintained at a slope of approximately 7:1.

Other conditions within an SEP will align to an approval condition set that allows for commensurate management of site-specific risk of erosion and sediment release and stormwater management.

2.1.4.2. Rehabilitation and decommissioning

The borrow pit will be restored by ripping the floor and sides to a depth of approximately 500 mm generally along the contour. Stockpiled topsoil and seed will then be re-spread to a uniform depth over the entire area from which it was removed. The sides and floor of the borrow pit will be graded to give a contoured finish.

At the end of operations, in addition to the above, borrow pits will be rehabilitated in accordance with the relevant conditions of the EA for PL 1055 (once granted).

3. Regional Attributes

The proposed Leghorn Dev C development is located in an arid to semi-arid region of central Australia where the average rainfall is low. The seasons in the region are characterised by dry, hot summers and short, dry winters.

Data from the Bureau of Meteorology (**BoM**) 'Orientos Station' weather station (station number 045024), which is located approximately 110 kilometres (**km**) south of the proposed Leghorn Dev C development, shows that (Queensland Government, 2024):

- During the summer months (December to February), the average maximum and minimum temperatures are 37.1 and 23.3 degrees Celsius (**°C**) respectively.
- During the winter months (June to August), the average maximum and minimum temperatures are 20.5°C and 7.1°C respectively.
- Average annual rainfall is 189 mm per year.
- The average summer and winter rainfall is 24.3 mm per month and 12 mm per month respectively.

The El-Nino Southern Oscillation (**ENSO**) exerts significant influence on inter-annual climate variability across the region, producing marked fluctuations in the amount, timing and distribution of rainfall. As such, there is considerable year-to-year variation in rainfall, particularly during the summer months which can range from 'failed' wet seasons to 'normal' and above average rainfall, and tropical cyclone activity.

3.2. Land Use

The proposed Leghorn Dev C development is located on Durham Downs (1SP133822). Durham Downs is an 8,910 square kilometre (**km²**) cattle station with a carrying capacity of 21,000 cattle (S.Kidman, 2024). The primary land uses within and surrounding the proposed Leghorn Dev C development on Durham Downs are cattle grazing and petroleum activities (refer to **Figure 3**) (ABARES, 2016).

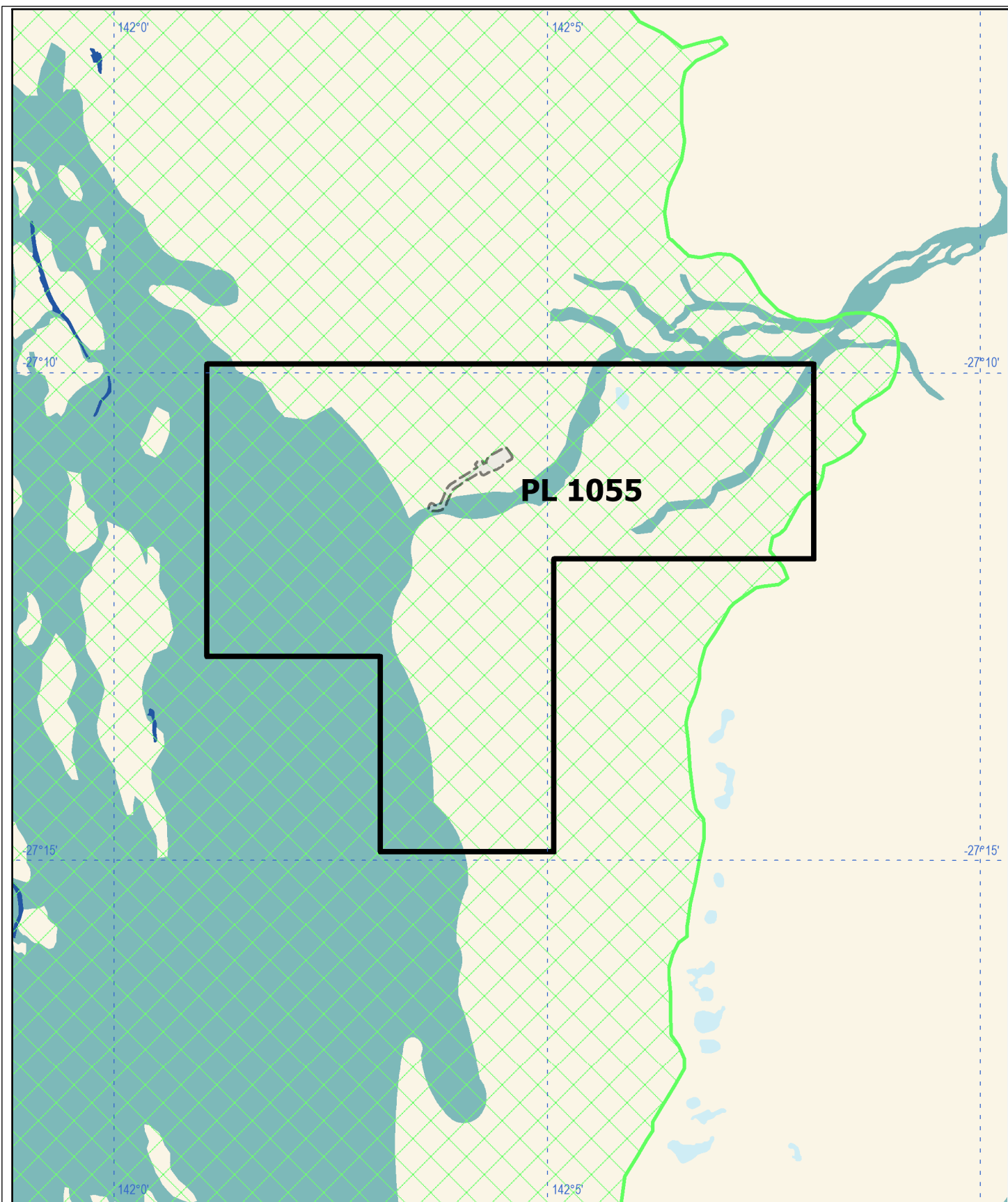

Santos has been carrying out petroleum activities on Durham Downs for some time, with a number of Santos owned and operated wells and associated infrastructure already present on these stations.



Legend

-  PL 1055
-  Strategic Environmental Area
-  Construction Disturbance Zone

Australian Land Use and Management Classification
Version 8 (October 2016)

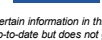
-  Grazing native vegetation
-  Lake
-  Marsh/wetland - production
-  River

Certain information in this map is provided under license from third parties and is subject to intellectual property rights. Santos has made every effort to ensure that information is accurate and up-to-date but does not guarantee or warrant the accuracy, completeness or currency of, and takes no responsibility for any error or omission relating to, this map. Santos and its related bodies corporate accept no responsibility for any errors or omissions. The "User" acknowledges that information and maps are in a constant state of change and accepts all limitations. To the maximum extent permitted by law, Santos and its related bodies corporate will not be liable for any cost, loss or damage arising out of the use of this map.

Santos

Cooper Basin

PL 1055

Land Use



0 4
kilometres



Figure 3: Land uses within and surrounding the proposed development

4. Environmental Attributes

Section 7 of the RPI Reg prescribes the following environmental attributes for the Channel Country SEA (current from 2 August 2024):

- a. *the natural hydrologic processes of the area characterised by—*
 - i. *natural, unrestricted flows in and along watercourse channels and the channel network in the area; and*
 - ii. *overflow from watercourse channels and the channel network onto the flood plains of the area, or the other way; and*
 - iii. *natural flow paths of water across flood plains connecting waterholes, lakes and wetlands in the area; and*
 - iv. *groundwater sources, including the Great Artesian Basin and springs, that support waterhole persistence and ecosystems in the area;*
- b. *the natural geomorphic processes of the area characterised by—*
 - i. *natural erosion; and*
 - ii. *the transport and deposit of sediment by water throughout the catchments and along the watercourse systems;*
- c. *the functioning riparian processes of the area characterised by native riparian vegetation associated with watercourses, lakes, flood plains and wetlands;*
- d. *the functioning wildlife corridors of the area characterised by—*
 - i. *natural habitat in the watercourse systems; and*
 - ii. *permanent waterholes and springs;*
- e. *the natural water quality in the watercourse channels and aquifers and on flood plains in the area characterised by physical, chemical and biological attributes that support and maintain natural aquatic and terrestrial ecosystems;*
- f. *the beneficial flooding of land that supports flood plain grazing and ecological processes in the area.*

The *Statutory Guideline 05/14: Carrying Out Resource Activity and Regulated Activity within a Strategic Environmental Area* (Queensland Treasury, 2020) summarises the above attributes to broadly relate to:

- Vegetation mapping
- Riparian processes and wildlife corridors
- Hydrological process and beneficial flooding
- Water quality
- Geomorphic processes

The relevance of the above environmental attributes to the proposed Leghorn Dev C development is described in the following sections.

4.1. Vegetation Mapping

4.4.1. Vegetation

Vegetation within and surrounding the proposed Leghorn Dev C development is State mapped as a variety of regional ecosystems (REs) (**Figure 4**) including:







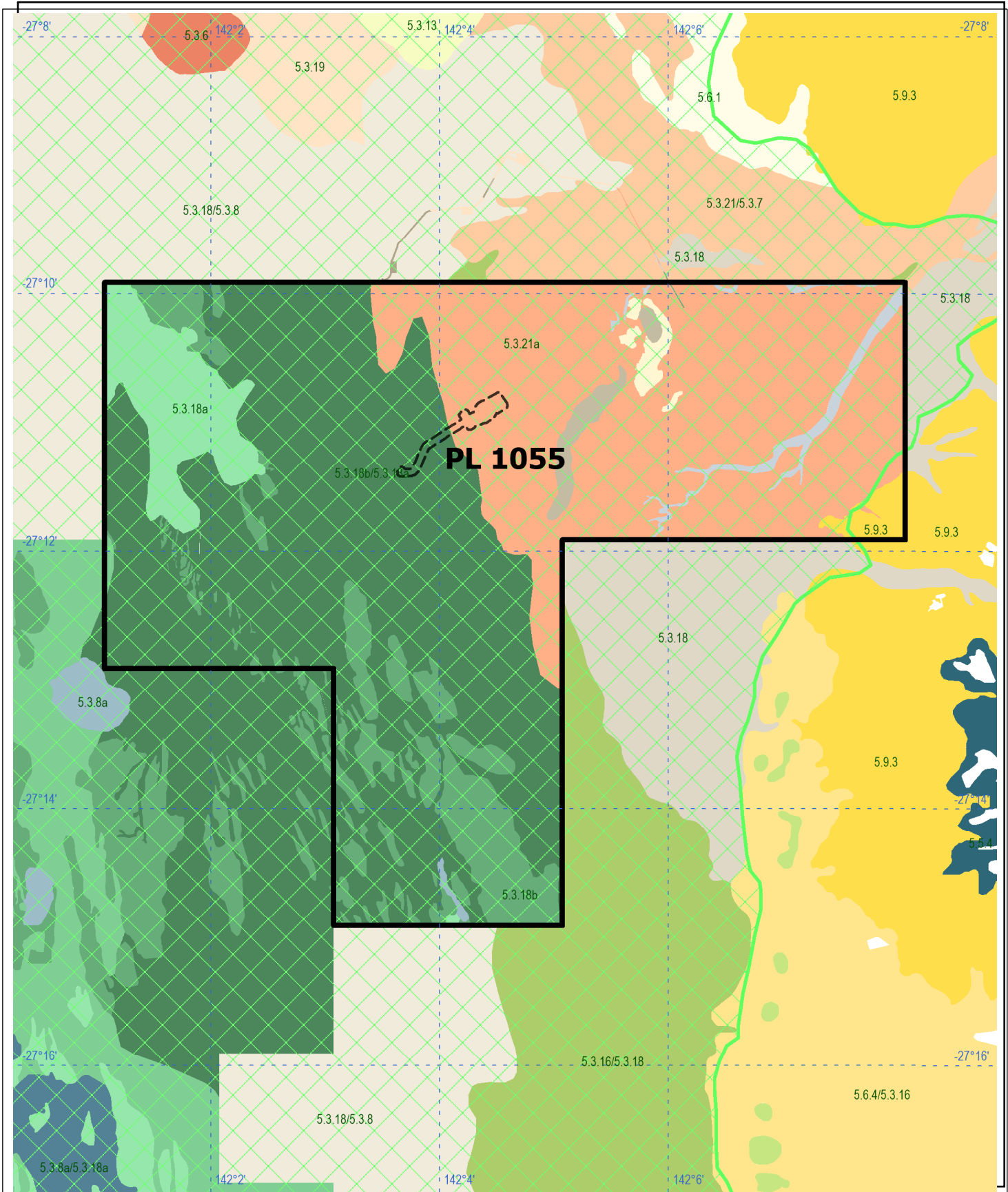



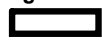

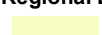











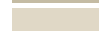

- RE 5.3.18 – Braided channel complex of major alluvial plains includes *Chenopodium auricomum* open shrubland and variable sparse to open-herbland.
- RE 5.3.8 – *Eucalyptus coolabah* low open woodland +/- *Duma florulenta* on braided channels, drainage lines, flood plain lakes and claypans.

- RE 5.3.16 – *Eragrostis australasica* sparse tussock grassland on intermittently inundated depressions on flood plains, interdune flats, clay pans and clay plains.
- RE 5.3.13 – *Duma florulenta* open shrubland in depressions on flood plains, interdune flats, clay pans and clay plains.
- RE 5.3.21 – Variable sparse to open herbland, *Senna spp.* open shrubland and bare scalded areas on infrequently flooded alluvia of major rivers their distributaries, drainage channels and creeks.

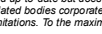
As above, these REs are classified as category B (remnant regulated vegetation) and have a 'least concern' vegetation management class and 'no concern at present' biodiversity status, as per Vegetation Management Act (**VM Act**) (1999).



Legend

 PL 1055	 Strategic Environmental Area	 Construction Disturbance Zone
Regional Ecosystems		
 5.3.13	 5.3.18a	 5.3.7
 5.3.13a	 5.3.18a/5.3.13a	 5.3.8a
 5.3.16	 5.3.18b	 5.3.8a/5.3.18a
 5.3.16/5.3.18	 5.3.18b/5.3.13a	 5.5.4
 5.3.16b	 5.3.19	 5.6.1
 5.3.17	 5.3.21/5.3.7	 5.6.4
 5.3.18	 5.3.21a	 5.6.4/5.3.16
 5.3.18/5.3.8	 5.3.6	 5.9.3

Certain information in this map is provided under license from third parties and is subject to intellectual property rights. Santos has made every effort to ensure that information is accurate and up-to-date but does not guarantee or warrant the accuracy, completeness or currency of, and takes no responsibility for any error or omission relating to, this map. Santos and its related bodies corporate accept no responsibility for any errors or omissions. The "User" acknowledges that information and maps are in a constant state of change and accepts all limitations. To the maximum extent permitted by law, Santos and its related bodies corporate will not be liable for any cost, loss or damage arising out of the use of this map.



Cooper Basin

PL 1055

Regional Ecosystems



0 3
kilometres

Rev 1 Date: 19/08/2024 File No. ENVIR 1022d.WOR



Figure 4: Regional ecosystems mapped within and surrounding the proposed development

4.2. Riparian Process and Wildlife Corridors

The construction and operation of Leghorn Dev C avoids all State-mapped riparian or terrestrial wildlife corridors (see **Figure 5**). By not intersecting primary wildlife corridors, the integrity of these areas is preserved, with no direct disturbance or alteration to their function.

4.2.1. Riparian Biodiversity Corridors



The proposed Leghorn Dev C development is located within the Channel Country bioregion. Riparian biodiversity corridors in the Channel Country bioregion were established with the intention of connecting permanent waterholes. They are based on major channels and minor channels (250 k geodata hierarchy 1, 2, and 3) necessary to capture permanent waterholes, buffered by 1 km either side and clipped to land zone 3 (DERM, 2009), and are associated with the Cooper Creek. The proposed Leghorn Dev C will avoid all biodiversity corridors within the area.

4.2.2. Terrestrial Biodiversity Corridors

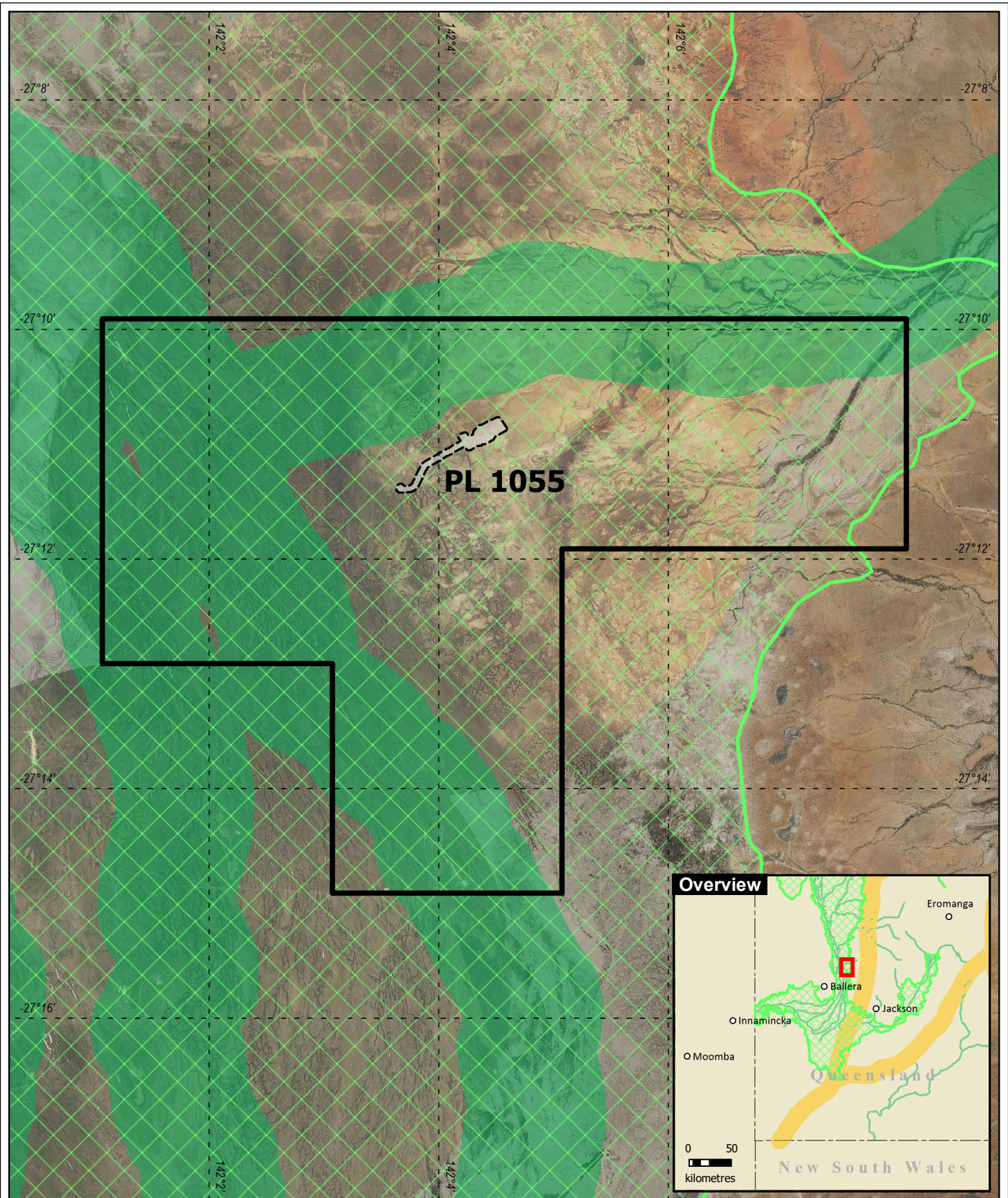

Terrestrial biodiversity corridors in the Channel Country bioregion aim to maximise connectivity between tracts of remnant vegetation. **Figure 5** shows closest terrestrial biodiversity corridor to the proposed Leghorn Dev C development is located approximately 24 km to the southeast (although the associated buffer is approximately 3 km to the east).



Legend

-  PL 1055
-  Strategic Environmental Area
-  Construction Disturbance Zone

Queensland statewide corridor

-  Terrestrial Corridor
-  Riparian Corridor

Certain information in this map is provided under license from third parties and is subject to intellectual property rights. Santos has made every effort to ensure that information is accurate and up-to-date but does not guarantee or warrant the accuracy, completeness or currency of, and takes no responsibility for any error or omission relating to, this map. Santos and its related bodies corporate accept no responsibility for any errors or omissions. The "User" acknowledges that information and maps are in a constant state of change and accepts all limitations. To the maximum extent permitted by law, Santos and its related bodies corporate will not be liable for any cost, loss or damage arising out of the use of this map.

Overview



Santos

Cooper Basin

PL 1055

Wildlife Corridors



Rev 1 Date: 19/08/2024 File No. ENVIR 1022e.WOR



Figure 5: Wildlife corridors within and surrounding the proposed development

4.3. Hydrological Processes & Beneficial Flooding

4.3.1. Regional Surface Water Hydrology

The proposed Leghorn Dev C development is situated in the Channel Country region of south-west Queensland. The Channel Country is characterised by vast flat lying, braided, flood and alluvial plains surrounded by gravel or gibber plains, dunefields and low ranges.

The hydrological and geomorphic processes in the Channel Country are dominated by Cooper Creek. Cooper Creek is approximately 1,500 km long and stretches from the Warrego Range in Queensland to Lake Eyre in South Australia. It has a catchment area of approximately 300,000 km².

Flows within Cooper Creek are usually confined to the main channel. However, during periods of high rainfall, Cooper Creek becomes a largely flooded plain with overland flows concentrating at the point where Cooper Creek crosses the Queensland – South Australia border. Contrastingly, during extended periods of no or little rainfall, Cooper Creek contracts to a series of isolated waterholes.

4.3.2. Local Surface Water Hydrology

As shown in **Figure 6** the proposed Leghorn Dev C development is located between waterways associated with Cooper Creek. The proposed development does not intersect any waterways; however, it is situated on the Cooper Creek floodplain meaning that the area is likely to experience intermittent overland flow during rainfall events, potentially resulting in localised ponding of surface water.

4.3.3. Wetlands

As shown in **Figure 6** the proposed Leghorn Dev C development intersects a natural lacustrine wetland. This wetland is associated RE 5.3.16b. The presence of water in this wetland is described as ephemeral and the dominant habitat is described as arid and semi-arid floodplain grass, sedge and herb swamps.

This wetland is classified as being of General Ecological Significance (**GES**). The closest wetland of High Ecological Significance (**HES**) to the proposed Leghorn Dev C development is located approximately 35 km to the south.

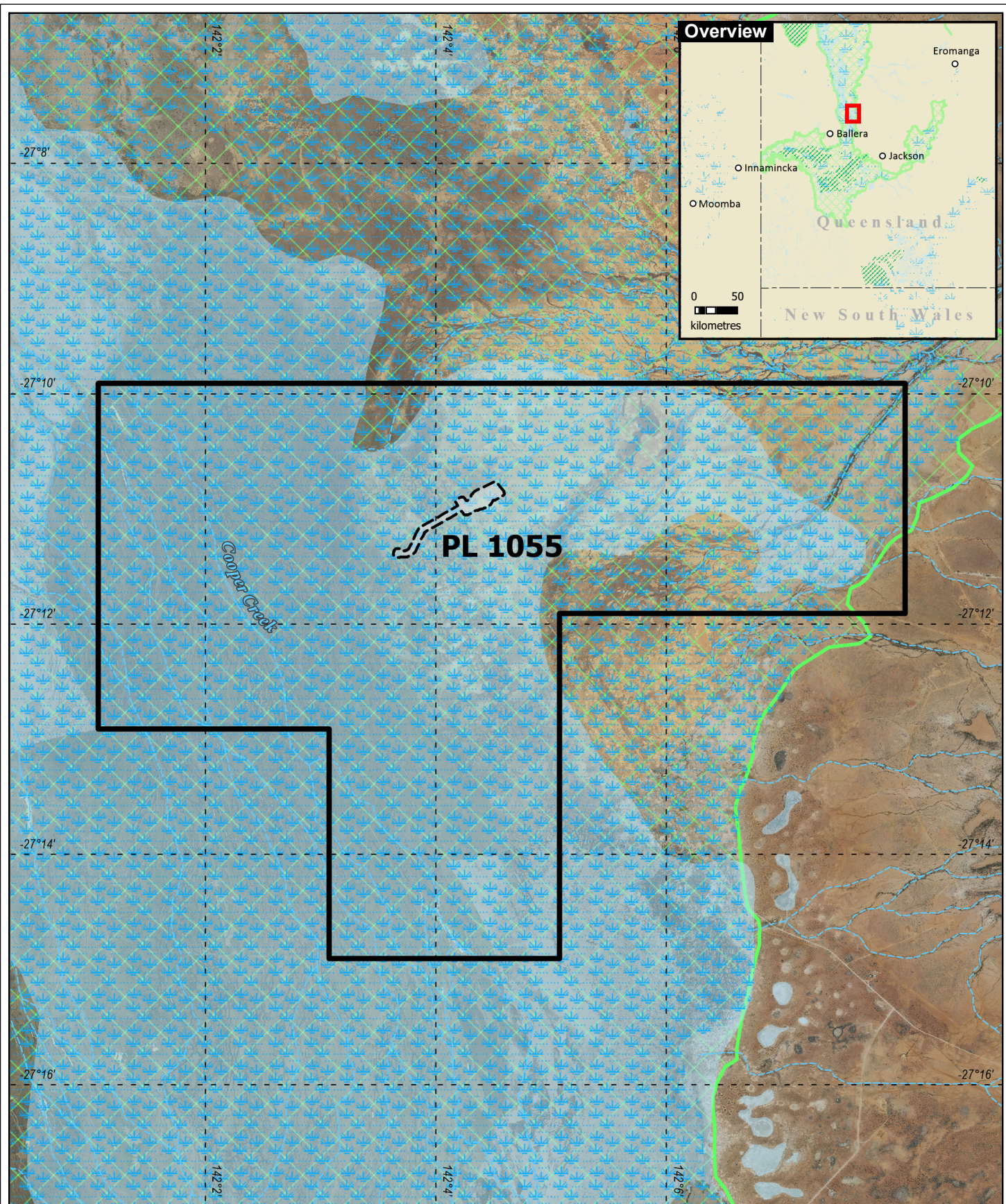

Legend



PL 1055



Strategic Environmental Area



Construction Disturbance Zone

--- Watercourse / drainage

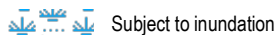

Subject to inundation

Wetland management area



High ecological significance (HES)



General ecological significance (GES)

Santos

Cooper Basin

PL 1055

Wetlands and Watercourses



Certain information in this map is provided under license from third parties and is subject to intellectual property rights. Santos has made every effort to ensure that information is accurate and up-to-date but does not guarantee or warrant the accuracy, completeness or currency of, and takes no responsibility for any error or omission relating to, this map. Santos and its related bodies corporate accept no responsibility for any errors or omissions. The "User" acknowledges that information and maps are in a constant state of change and accepts all limitations. To the maximum extent permitted by law, Santos and its related bodies corporate will not be liable for any cost, loss or damage arising out of the use of this map.

Figure 6: Wetlands and watercourses in the vicinity of the proposed development

4.3.4. Fish Passage

Queensland waterways for water barrier works mapping shows that the proposed Leghorn Dev C development does not intersect any waterways that, under the *Fisheries Act 1994*, provide for fish passage.

4.3.5. Regional Groundwater Hydrology

The proposed Leghorn Dev C development is situated within the Eromanga Basin within the Great Artesian Basin (**GAB**). The main GAB aquifers (i.e. in the Eromanga Basin stratigraphy) in relation to the proposed development is the Hutton Sandstones. The proposed development is also potentially situated within the Toolachee and Epsilon Formations within the Cooper Basin. The aquifers of the Eromanga Basin and Cooper Basin are considered highly productive aquifers.

Shallow groundwater is generally found within the Quaternary and Tertiary alluvium formations associated with the very flat structures of flood plains and is absent where the Winton Formation occasionally outcrops. Groundwater from Tertiary sediments and the Winton Formation is characterised by relatively high concentrations of sodium and magnesium, with Electrical Conductivity (**EC**) concentrations ranging from 900 to 13,000 $\mu\text{S}/\text{cm}$ (Golder Associates, 2019).

As per the Code of Practice (2019), Santos will isolate all shallower aquifers and reservoir with API class cement behind production and surface casing.

The proposed disturbance is a relatively small footprint when compared to the total area of the SEA, local aquifers, and the GAB. Nevertheless, the isolation measures on shallow aquifers implemented during construction and operation of the proposed development will avoid potential impacts on natural hydrologic processes of groundwater sources.

4.3.6. Local Groundwater Hydrology

Within Santos' tenements in the Cooper Basin, only the upper aquifers of the Eromanga Basin sequence are of economic interest to the local community. This is due to the significant depth of the water bearing formations in the Cooper Basin and the general unreliability of the groundwater quality that may be encountered (i.e. it may have a high salinity and contain free and dissolved hydrocarbons).

Registered groundwater bores in the vicinity of the proposed Leghorn Dev C development confirm the significant depth of water bearing formations in the region. There are nine (9) registered groundwater bores within an approximately 12 km radius of the proposed development with a median depth of 2,366 m excluding those with no depth data:

- RN 116408 (11.2 km away, 126.0 m depth)
- RN100332 (6 km away, no depth data)
- RN2424 (10.2 km away, 904.65 m depth)
- RN100277 (9 km away, no depth data)
- RN100278 (10.3 km away, no depth data)
- RN23101 (11.7 km away, 2591.7 m depth)
- RN23494 (8.7 km away. 2426.2 m depth)
- RN23823 (11.3 km away, 2478.3 m depth)
- RN23610 (11.9 km, 2305.8 m depth)

4.3.7. Groundwater Dependent Ecosystems

No surface expression or subterranean Groundwater Dependent Ecosystems (**GDEs**) are mapped in close proximity to the proposed Leghorn Dev C development. However, a derived terrestrial GDE and potential GDE aquifers (unconsolidated sedimentary aquifers) underlies the proposed development (refer **Table 3**).

Table 3: Groundwater Dependant Ecosystems

Type of GDE	GDE Rule Set Name	GDE Confidence
Derived Terrestrial GDE	Quaternary alluvial aquifers with brackish, ephemeral groundwater connectivity regime	Moderate
Potential GDE Aquifers (Unconsolidated sedimentary aquifers)	Quaternary alluvial aquifers with brackish, ephemeral groundwater connectivity regime	Moderate

4.4. Water Quality

Historical (1965 – 2023) water quality data from the Queensland Government’s Cooper Creek gauging station (station number 003103A) is summarised in **Table 4** (Queensland Government, 2024). This gauging station is located approximately 100 km south-west of the proposed Leghorn Dev C development; it is the closest gauging station to the proposed development.

Table 4: Cooper Creek Surface Water Quality (1965 – 2023)

Parameter	Average Value
Conductivity @ 25°C	298 µS/cm
Turbidity	526 NTU
pH	7.4
Total Nitrogen	1.2 mg/L
Total Phosphorus as P	0.3 mg/L
Sodium as Na	37.2 mg/L
Magnesium as Mg	6.3 mg/L
Chloride as Cl	59.5 mg/L
Fluoride as F	0.02mg/L

4.5. Geomorphic Processes

4.3.1. Regional

Surface geology in the Channel Country is dominated by Quaternary alluvium deposits associated with flood plains, with consolidated Tertiary sediments or Winton Formation on the higher ground. Cooper Creek is a large sedimentary sump accreting over a vast floodplain. Fluvial processes also play a role in the geomorphology of the Channel Country as evidenced by the presence of isolated sand dunes.

4.3.2. Local

According to RE mapping, the dominant land zone within and surrounding the proposed Leghorn Dev C development is land zone 3 (Cainozoic alluvial plains and piedmont fans). Additional land systems mapping, completed as part of the Western Arid Region Land Use Study – Part 1 (DESI, 2024), indicates the proposed development traverses two land systems, C1 and A4 as described in **Table 5**.

The dominant soils surrounding the proposed Leghorn C development, as mapped by the Atlas of Living Australian Soils (1:2,000,000 scale), are CC87 (floodplains of major rivers consisting of numerous braided stream channels that are seasonally flooded) and CC88 (clay plains marginal to major rivers; subject to seasonal inundation for the greater part some sand dune & sand hill areas).

Table 5: Land Systems

Development	Map Code	Land System Description	Agricultural Land Class
Leghorn Dev C	C1	Flooded alluvial plains with anastomosing channels; bluebush, lignum herbaceous low open shrubland; herbfield; and coolibah, lignum shrubby woodland on the major channel; cracking grey clays throughout	C2 (pastureland – native pastures)
	A4	Flooded alluvial plains with eroded low dunes less than 1.5 metres high, shrubby herbfield of short grass, bassia, saltbush and bluebush in the depressions, herbfield and sparse vegetation on the low dunes; grey clays and claypans on the plains, scalded sandy loam surfaced texture contrast soils and yellow sands on the low dunes.	

5. Potential Impacts to Environmental Attributes and Proposed Mitigation

The below sections describe potential impacts on the environmental attributes of the SEA as a result of the Leghorn Dev C development, as well as how the potential impacts will be avoided, minimised and mitigated.

5.1. Riparian Processes and Wildlife Corridors

The proposed Leghorn Dev C development is expected to require minimal vegetation clearing. The REs mapped within and in close proximity to the proposed development are likely to be naturally ephemeral and resilient to disturbance, having adapted to the boom-and-bust periods associated with the Channel Country bioregion. The REs are likely to respond well to rehabilitation conditions.

The proposed Leghorn Dev C development is considered unlikely to compromise riparian processes as Santos would implement measures to ensure that the proposed development does not compromise vegetation processes associated with streams, lakes, floodplains and wetlands.

Vegetation disturbance will be minimised as far as practicable by:

- Co-locating new infrastructure with existing infrastructure, and refining the location of new infrastructure within the CDZ to reduce the extent of clearing;
- Lopping/trimming branches rather than removing mature trees and shrubs.
- Clearing will not extend beyond the CDZ.
- Chemicals and fuels will be stored and handled in accordance with Australian Standards and spill kits will be available on site to contain any spills should they occur.
- Measures will be implemented to prevent fauna entrapment within excavation work areas, such as restricting the length of open trenches to the minimum required at any one time, ensuring breaks/bridges are installed as required for cattle and wildlife egress, and ensuring a cellar cover is installed at the new wells as soon as reasonably practicable.
- Access to and from authorised activities will occur along designated access tracks only, with speed limits implemented to reduce the likelihood of vehicle strike from fauna injuries and fatalities amongst other indirect impacts (e.g. dust and erosion).
- Rehabilitation to promote conditions suitable for the natural revegetation of disturbed areas will occur progressively.
- Infrastructure/disturbances with no future use will be rehabilitated as soon as reasonably practicable following the cessation of petroleum activities to promote the natural re-establishment of vegetation of similar species composition and density to the surrounding undisturbed land in accordance with the relevant EA conditions for PL 1055 (once granted).

Given the characteristics of the vegetation to be cleared, the relatively small disturbance footprint and the implementation of the above listed management measures, the proposed Leghorn Dev C development is considered unlikely to cause widespread or irreversible impacts on riparian function within the Channel Country SEA.

5.2. Hydrological Processes & Beneficial Flooding

The proposed Leghorn Dev C is considered unlikely to affect the existing hydrological processes and beneficial flooding of the Channel Country SEA given it does not intersect any waterways and it has a relatively small disturbance footprint when compared to the total area of the Channel Country SEA. Nevertheless, the following measures will be implemented during construction and operation of the proposed development to avoid, minimise and/or mitigate potential impacts on hydrological processes and beneficial flooding:

- Infrastructure associated with drilling will be largely temporary and drilling will be scheduled outside periods of inundation and/or flooding.

- Surface excavations, such as the drilling fluid sumps and borrow pits, have the potential to result in diversion or interception of a negligible amount of overland flow. Both types of surface excavations are relatively small compared to the surrounding catchment and will be designed to exclude overland flow. They will also be temporary and scheduled to be completed when no surface water is expected to be present on site and outside of flood events/inundation periods.
- A primary control measure is locating borrow pits out of flood ways / channels where possible. Where no reasonable or practicable alternative exists, Santos preferentially locates borrow pits in pre-existing areas of clearing or significant disturbance. The order of preference is captured during the planning stages of proposed development.
- Please refer to **Section 2.1.4** for specific information relating to the construction of borrow pits and mechanisms to exclude overland flow.
- Drilling fluids would be removed from site, and surface excavations for drilling fluid sumps and borrow pits will be backfilled within six (6) months of the completion of drilling and will be designed to exclude overland flow. These activities are temporary and will be scheduled to be completed when no surface water is expected to be present within the development and outside of flood events/inundation periods.
- Please refer to **Section 2.1.1.1.1** for specific information relating to drill fluid management.
- Workover operations may occur throughout well operation. The infrastructure and activities required for (and therefore potential impacts of) well workovers are similar to those required for initial well drilling. These will also be temporary and conducted outside of periods of inundation. Following workover operations, drilling fluids and workover equipment will be removed from site and drilling fluid sumps backfilled.
- Access tracks will not be constructed to any flood immunity to allow the natural flow of surface water across the development.
- Please refer to **Section 2.1.3** for specific information relating to management of the various stages related to access tracks.
- The proposed pipelines will be buried and the surface rehabilitated following construction to reinstate natural drainage patterns and promote the natural re-establishment of vegetation consistent with the surrounding undisturbed land.
- Following cessation of petroleum production, existing infrastructure will be rehabilitated to promote natural re-establishment of vegetation consistent to the surrounding undisturbed land.
- The management of erosion and sediment during the life of the project will be managed through the implementation of an SEP and regular inspections during construction phases. Management tools include current weather forecasts, with any pending wet weather to be taken into consideration prior to undertaking any civil works, particularly in relation to topsoil stripping and works within a drainage feature or watercourse.

5.3. Water Quality

As stated above, the proposed Leghorn Dev C development does not intersect any waterways; however, it is situated on the Cooper Creek floodplain and the local area is likely to experience intermittent overland flow during rainfall events. Vegetation removal, earthworks, and site access associated with the proposed development may increase the erosion potential of the local area, which in turn may increase sedimentation of surrounding waterways and wetlands.

The following measures will be implemented during construction and operation of the proposed development to avoid, minimise and/or mitigate potential impacts on water quality:

- Erosion and sediment controls will be installed as necessary and as required by the conditions of the EA for PL 1055 (once granted).
- Clearing of shrubs and large trees will be avoided where practical to aid in the retention of top-soil integrity and stability and facilitate biodiversity.
- Areas under construction which include bare soil, but are not actively being worked on, will be covered up or banded with suitable products to prevent erosion or sediment runoff.
- Rehabilitation will occur progressively during construction to further reduce disturbance levels and erosion potential of the local area.
- Construction will be scheduled with consideration to seasonal conditions and rainfall/flood risk.

- Construction will not commence if the local area is inundated, and if the local area is at risk of becoming inundated, works will cease and construction areas will be secured until the inundation has subsided (this will include removing all non-essential materials (e.g. hydrocarbons, chemicals and infrastructure) present on site). It is noted that due to the slow-moving nature of flood waters in the Cooper Creek catchment, sufficient time is generally available to prepare local areas for potential flood impacts.
- The proposed development will not involve the discharge of water (i.e. point or diffuse sources), or the construction or operation of regulated dams or other major water generating/storage infrastructure (i.e. separator ponds, permanent camps). Hydrotest water will not be released to land; it will only be transported to the nearest licenced facility for treatment and/or disposal.
- All fuels/chemicals used on site will be stored and handled in accordance with applicable Australian Standards. Spill kits will be available on site, at each operational area to contain any spills should they occur. Procedures for responding to and investigating spills should they occur will be developed and implemented as required by the conditions of the EA for PL 1055 (once granted).
- All waste materials and non-essential infrastructure will be removed from site as soon as reasonably practicable following the cessation of construction.

5.4. Geomorphic Processes

As discussed in **Section 4.2**, the proposed Leghorn Dev C development has the potential to increase the erosion potential of the local area, particularly during construction. This is considered unlikely to significantly affect geomorphic processes given the small area of proposed disturbance relative to the total area of the Channel Country SEA, and the temporary nature of construction during which erosion potential is at its highest. Santos is committed to managing and reducing any environmental impacts and will implement the following measures during construction and operation of the proposed development to avoid, minimise and/or mitigate potential impacts on geomorphic processes:

- The proposed flowlines will be buried.
- Construction activities will be undertaken outside of periods of inundation and impending wet weather.
- The total area of disturbance and vegetation clearing will be minimised by co-locating new infrastructure with existing infrastructure where possible.
- Access tracks will be designed without flood immunity to allow maintenance of natural overland flows.
- The ground surface will be rehabilitated progressively during construction, reducing the potential for erosion and sedimentation. Rehabilitation will aim to reinstate the natural drainage features, micro-contours, and re-establish vegetation consistent with the surrounding undisturbed land such that natural erosion, sedimentation and depositional processes are maintained in the long-term.

6. Required Outcome Assessment

Table below demonstrates that the proposed Leghorn Dev C development meets the required outcome and prescribed solution for SEAs in Schedule 2, Part 5 of the RPI Act.

Table 6: Requirements of Schedule 2, Part 5 of the RPI Act

Schedule 2, Part 5 RPI Act	Relevance to Application
<p>14 Required outcome <i>The activity will not result in a widespread or irreversible impact on an environmental attribute of a strategic environmental area.</i></p>	<p>✓ As outlined in Section 4 of this report, the proposed Leghorn Dev C development has been designed to (in preferential order) avoid, minimise and mitigate potential impacts on the environmental attributes of the SEA. The potential impacts will not be widespread or irreversible.</p>
<p>15 Prescribed solution 1. <i>The application demonstrates either—</i> a. <i>the activity will not, and is not likely to, have a direct or indirect impact on an environmental attribute of the strategic environmental area; or</i> b. <i>all of the following—</i></p>	<p>✓ The application demonstrates that the proposed Leghorn Dev C development will be undertaken in accordance with the prescribed solution provided in Schedule 2, Part 5, Item 15 (1)(b) of the RPI Reg, as outlined below.</p>
<p><i>i. if the activity is being carried out in a designated precinct in the strategic environmental area—the activity is not an unacceptable use for the precinct;</i></p>	<p>✓ The proposed Leghorn Dev C development does not include any of the unacceptable uses prescribed by Schedule 2, Part 5, Item 15 (2) of the RPI Reg.</p>
<p><i>ii. the construction and operation footprint of the activity on the environmental attribute is minimised to the greatest extent possible;</i></p>	<p>✓ As outlined in Section 2.1 of this report, the location of the new wells and supporting infrastructure for the proposed Leghorn Dev C development has been selected in accordance with the following site planning principles:</p> <ul style="list-style-type: none"> • Maximise the use of areas of pre-existing disturbance. • In order of preference, avoid, minimise and mitigate any impacts, including cumulative impacts, on areas of native vegetation and other areas of ecological value. • Minimise disturbance to land that may result in land degradation. • In order of preference, avoid then minimise isolation, fragmentation, edge effects and dissection of tracts of vegetation. • In order of preference, avoid then minimise clearing of native mature trees. • Maximise co-location of linear infrastructure corridors. • Minimise the width of linear infrastructure corridors to the greatest practicable extent. <p>Application of these site planning principles has been demonstrated throughout Section 2 to 4 of this report.</p>
<p><i>iii. the activity does not compromise the preservation of the environmental attribute within the strategic environmental area;</i></p>	<p>✓ As outlined in Section 4 of this report, the proposed Leghorn Dev C development has been designed to (in preferential order) avoid, minimise and mitigate potential impacts on the environmental attributes of the SEA.</p>
<p><i>iv. if the activity is to be carried out in a strategic environmental area identified in a regional plan—the activity will contribute to the regional outcomes, and be consistent with the regional policies, stated in the regional plan.</i></p>	<p>✓ The Channel Country SEA is not identified in the Southwest Regional Plan.</p>

7. References

- ABARES. (2016). *The Australian Land Use and Management Classification Version 8*.
- DERM. (2009). *Biodiversity Planning Assessment, Channel Country Bioregion, Landscape Expert Panel Report, Version 1.1*.
- DESI. (2024, February 9). *Western Arid Region Land Use Study (WARLUS), South West Queensland Part 1 - AWA2*. Retrieved from Queensland Government Publications Portal: <https://www.publications.qld.gov.au/dataset/land-systems-warlus-awa2>
- DSDMIP. (2019). *RPI Act Statutory Guideline 01/14: How to make an assessment application for a regional interests development approval under the Regional Planning Interests Act 2014*.
- Golder Associates. (2019). *Underground Water Impact Report for Santos Cooper Basin Oil & Gas Fields, SW QLD*.
- Queensland Government. (2024, February 9). *Water Monitoring Information Portal*. Retrieved from Queensland Government.
- Queensland Government. (2024, February 12). *SIL0 - Australian climate data from 1889 to yesterday*. Retrieved from Queensland Government: <https://www.longpaddock.qld.gov.au/silo/point-data/#responseTab2>
- Queensland Treasury. (2020). *RPI Act Statutory Guideline 05/14: Carrying out resource activities and regulated activities in a Strategic Environmental Area*.
- S.Kidman. (2024, February 8). Retrieved from Station Hand - Naryilco Advertisement: <https://www.kidman.com.au/wp-content/uploads/2020/10/Naryilco-Station-Hand-JAN2021.pdf>

Appendix A – Proposed Well Lease Layout During Drilling

LEASE INFO	
LEASE DISTURBANCE AREA	10,303m ²
OFF LEASE DISTURBANCE AREA EXCLUSION ZONE	1,883m ²
CAPPING AREA EXCLUDING HARDSTAND & SUMP	7,710m ²
RIG HARDSTAND	486m ²
SUMP VOLUME	672m ³
SUMP AREA	224m ²

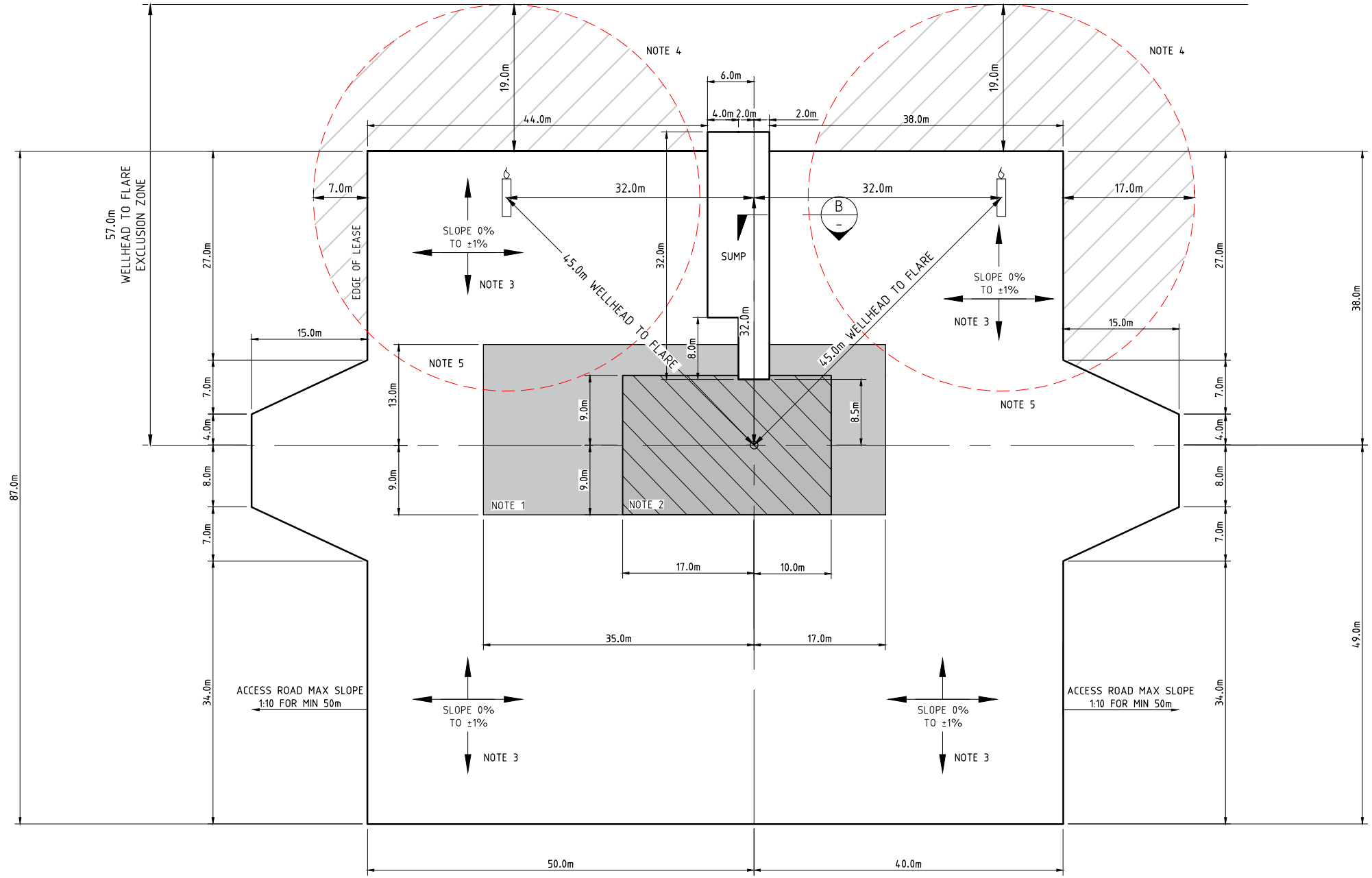
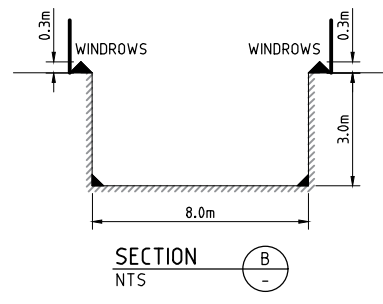

- NOTES:**
- LEASE LEVEL TOLERANCE IN RIG PAD AREA (GREY SHADED) = +/- 50mm - 15mm MAX DIFFERENCE ACROSS ANY 3m LENGTH. GROUND COMPACTION TO BE FIRM ENOUGH TO SUPPORT RIG.
 - RIG HARDSTAND PAD AREA (DIAGONAL HATCHED) TO FILLED WITH 600mm SUITABLE MOISTURE CONDITIONED CLAY AND COMPACTED. LEVEL TOLERANCE TO BE +/- 20mm, 10mm MAX DIFFERENCE ACROSS ANY 3m HEIGHT.
 - GRADIENTS OF +/- 1% CAN BE USED ACROSS THE LEASE IN ALL AREAS OTHER THAN THOSE COVERED BY NOTE 1.
 - OFF LEASE AREAS TO HAVE VEGETATION CLEARED TO ENSURE COMPLIANCE WITH FLARE STACK EXCLUSION ZONE.
 - DASHED RED CIRCLE REPRESENTS 25m EXCLUSION ZONE AROUND 2 X POSSIBLE FLARE LOCATIONS. WHERE POSSIBLE FLARE LOCATION TO BE SPECIFIED.

PLAN
SCALE 1:250

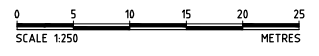

No	DATE	DRN	CHKD	ENG	Q.A.	PROJ	ACC	CP	DESCRIPTION	DRG No.	SUBJECT
0	20/08/20	FYF	GDA	-	-	-	-	-	ISSUED FOR CLIENT REVIEW	-	-
REVISIONS										REFERENCE DRAWINGS	

DRN:	FYF
DATE:	20/08/20
SCALE:	1:250
CHKD:	GDA
ENG:	-
Q.A.:	-
PROJ:	-
ACC:	-
A.B.N.	80 007 550 923

FLARE STACK EXCLUSION ZONES
ENSIGN 967 RIG



DRAWING No.	REV
	A

Appendix B – Typical Buried Pipeline Right-of-Way

Appendix C – Typical Road Cross Section for Class D Roads

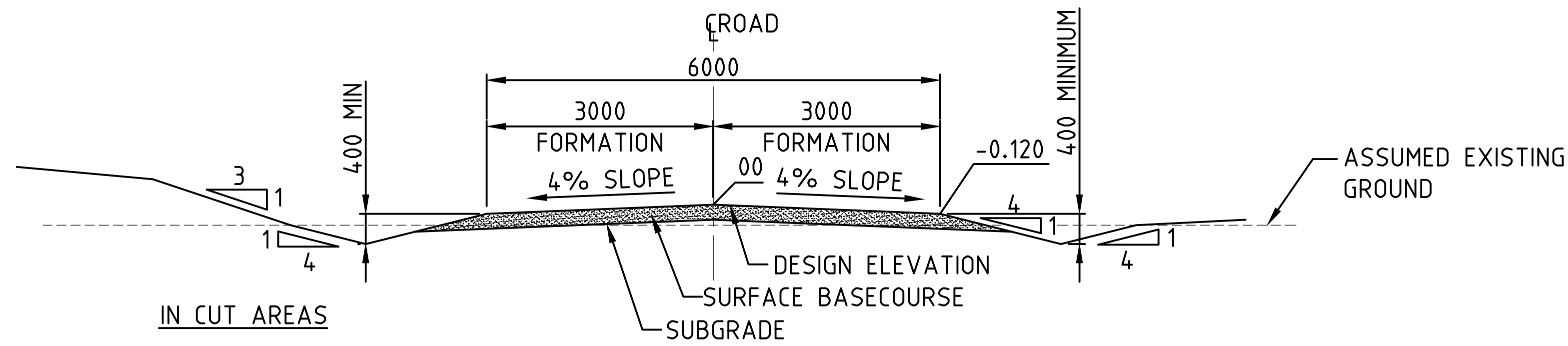

PAVEMENT MATERIAL - CLASS C ROAD

SURFACE COURSE	MINIMUM 200mm BEST AVAILABLE LOCAL (CLAY OR CLAYEY SAND) MATERIAL, COMPACTED TO 95% MMDD @ +/- 2% OMC.
SUBGRADE	REMOVE ALL VEGETATION AND COMPACT 200mm SUBGRADE TO 95% MMDD @ +/- 2% OMC.

TYPICAL SECTION - CLASS D ROAD (FOR ELEVATED SECTIONS)

SCALE 1:50

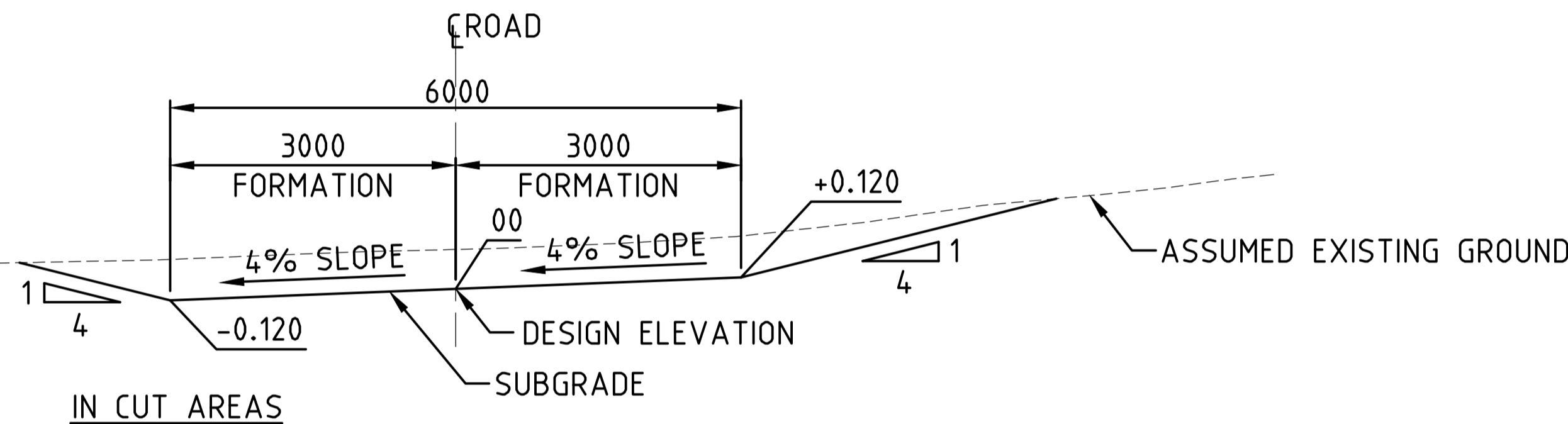

TYPICAL SECTION - CLASS D ROAD (FOR SECTIONS GRADED TO HARD SURFACE)

SCALE 1:50

ROAD CONDITION	MIN. VERTICAL CURVE LENGTH (m)	
	CLASS D	CLASS D 30kph*
1	80	30
2	80	30
3	90	30
4	120	30
5	150	30
6	180	30
7	210	40
8	240	40
9		50
10		55

CLASS D ROADS, SAND DUNE CROSSINGS

ROAD CONDITION	SPEED LIMIT	MIN. HORIZONTAL CURVE LENGTH (m)
CLASS D ROAD	80kph	500

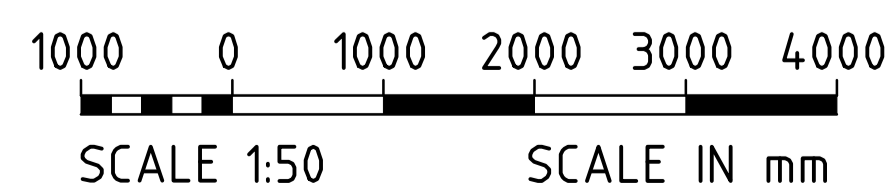

No	DATE	DRN	CHKD	ENG	Q.A.	PROJ	ACC	DESCRIPTION	DRG No.	SUBJECT	REFERENCE DRAWINGS
C	07/11/17	FYFE	SJM					UPDATED FOR CLIENT REVIEW			
B	01/04/16	FYFE	SJM					REVISED FOR REVIEW UNDER MOC-CB-002992			
A		KBR	BC					ISSUED FOR CLIENT REVIEW			

NOTES:

- THIS DRAWING TO BE READ IN CONJUNCTION WITH ALL THE COMPLETE CONTRACT DOCUMENTS AND SPECIFICATIONS.
- ALL DIMENSIONS ARE IN MILLIMETRES UNLESS NOTED OTHERWISE.
- FOR SITE PREPARATION, EXCAVATION AND BACKFILL REFER TO PROJECT SPECIFICATION.
- FOR ROAD CONSTRUCTION REFER TO ROAD WORKS SPECIFICATION 1515-120-S006.
- SIDE BATTER SLOPES FOR CLASS D ROAD SHALL BE 4 HORIZONTAL TO 1 VERTICAL IN CUT AND FILL.
- CLEARING, GRUBBING AND STRIPPING OF FULL DEPTH (MIN. 100mm) OF TOPSOIL WITHIN THE ROAD RIGHT OF WAY SHALL BE UNDERTAKEN FOR THE NEW ROAD ALIGNMENTS.
- FOR CLASS D ROAD, FORMATION ELEVATED TO PROVIDE STABLE RUNNING SURFACE NO PROVISION FOR DRAINAGE.

ROAD CLASSES	D
ROAD WIDTH - METRES	
NORMAL WIDTH	6.0
SAND DUNE CROSSING	8.0
CULVERT/FLOODWAY	8.0

- TABLE DRAINS. TABLE DRAINS SHALL MITRE AT THE FOLLOWING SPACING.

RECOMMENDED MITRE DRAIN SPACING		
SLOPE		SPACING (m) (MAXIMUM)
%	GRADIENT	
0.5	1 : 200	120
1	1 : 100	120
2	1 : 50	100
3	1 : 33	80
4	1 : 25	60
5	1 : 20	60
6	1 : 17	50
8	1 : 12.5	30

- MINIMUM INVERT OF TABLE DRAIN TO BE BELOW PAVEMENT SUB-GRADE LEVEL.
- VERTICAL GRADE ON DUNE APPROACH ROADS TO BE LIMITED TO (10% MAX.) 6% VERTICAL GRADIENT PREFERRED.

CIVIL STANDARD DRAWING
TYPICAL ROAD CROSS SECTION
CLASS D ROADS

Santos DRAWING No. 0001-040-DDR-0005 REV C